

# Mass Spectrometry in Structural and Stereochemical Problems. LXV.<sup>1</sup> Synthesis and Fragmentation Behavior of 15-Keto Steroids. The Importance of Interatomic Distance in the McLafferty Rearrangement<sup>2</sup>

Carl Djerassi, G. von Mutzenbecher,<sup>3a</sup> J. Fajkos,<sup>3b</sup>  
D. H. Williams, and H. Budzikiewicz

Contribution from the Department of Chemistry, Stanford University,  
Stanford, California. Received October 19, 1964

A new synthesis of 15-keto steroids from readily available 17-keto precursors is described, the key step being the hydrazine reduction of the 15 $\beta$ ,16 $\beta$ -oxido-17-ketone IX to the  $\Delta^{16}$ ,15 $\beta$ -alcohol X. The pure 14 $\alpha$ - (XII) and 14 $\beta$ - (XV) isomers of 5 $\alpha$ -androstan-15-one were prepared and the position of the base-catalyzed equilibrium (85% 14 $\beta$  vs. 15% 14 $\alpha$ ) established by optical rotatory dispersion measurements. 15-Keto steroids are excellent models for examining the operation of steric factors in the McLafferty rearrangement after electron impact. While the formation of the most important ion (*m/e* 97) in the mass spectrum (Figure 2) of 5 $\alpha$ -androstan-15-one (XII) can be readily interpreted on the basis of a McLafferty rearrangement involving transfer of the 7 $\beta$ -hydrogen atom, appropriate deuterium labeling shows that a different mechanism operates. The importance of the interatomic distance between the departing hydrogen and the receptor oxygen atoms in the McLafferty rearrangement is emphasized. The stereochemistry of the deuterium atom in 5 $\alpha$ -androstan-15-one-7 $\beta$ -d<sub>1</sub> (XXIV) is supported by various n.m.r. measurements which also shed light on the deshielding of the 7 $\beta$ -proton by the 15-keto group.

## Introduction

One of the most general electron impact induced reactions of carbonyl compounds (*e.g.*, esters or ketones) possessing a hydrogen atom in the  $\gamma$ -position is the cleavage of the  $\alpha,\beta$ -bond with transfer of the  $\gamma$ -hydrogen atom. The generality of this process, which may be depicted<sup>4</sup> in terms of structures A and B, was first recognized by McLafferty<sup>5</sup> and has recently been reviewed in various contexts.<sup>6-9</sup>

(1) Paper LXIV: A. M. Duffield, H. Budzikiewicz, D. H. Williams, and C. Djerassi, *J. Am. Chem. Soc.*, **87**, 810 (1965).

(2) Supported by the National Institutes of Health (Grants No. CA-07195 and AM-04257) and the Rockefeller Foundation (fellowship support for J. F.). Grateful acknowledgment is also made to Syntex S.A., Mexico City, for a generous supply of steroid starting materials.

(3) (a) Recipient of a travel grant from the Swiss-American Foundation for Scientific Exchange. (b) Visiting Investigator from the Czechoslovak Academy of Sciences, Prague.

(4) For notations employed see H. Budzikiewicz, C. Djerassi, and D. H. Williams, "Structure Elucidation of Natural Products by Mass Spectrometry," Vol. I, Holden-Day, Inc., San Francisco, Calif., 1964, pp. 1-3.

(5) F. W. McLafferty, *Anal. Chem.*, **31**, 82 (1959).

(6) K. Biemann, "Mass Spectrometry," McGraw-Hill Book Co., Inc., New York, N. Y., 1962, Chapter 3.

(7) S. Meyerson and J. D. McCollum in "Advances in Analytical Chemistry and Instrumentation," C. N. Reilly, Ed., Interscience Publishers, Inc., New York, N. Y., 1963, pp. 184-199.

(8) H. Budzikiewicz, C. Djerassi, and D. H. Williams, "Interpretation of Mass Spectra of Organic Compounds," Holden-Day, Inc., San Francisco, Calif., 1964, Chapter 1.

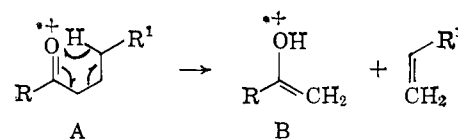

The origin of the transferred hydrogen from the  $\gamma$ -carbon atom has been established by extensive deuterium labeling,<sup>10</sup> but it should be noted that all of the labeled model compounds were either aliphatic<sup>10a-c,e</sup> or of such a nature (I)<sup>10d,f</sup> that the hydrogen atom could approach rather closely to the oxygen atom. When a molecule of rigid geometry, such as 5 $\alpha$ -androstan-11-one (II), was examined in terms of various deuterium-labeled analogs,<sup>11</sup> the surprising observation was made that the  $\gamma$ -hydrogen atoms did not participate to any important extent in the fission of the 9-10 bond. The conclusion was reached,<sup>12</sup> therefore, that the interatomic distance between the departing hydrogen atom and the receptor oxygen atom plays a crucial role (1.5 Å. in I as compared to 1.8 Å. in II).

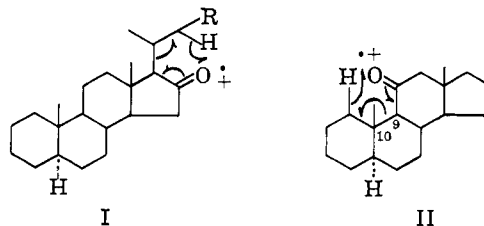

We felt that it would be important to examine another test case, which should potentially undergo the McLafferty rearrangement (A  $\rightarrow$  B) and where the interatomic distance between the  $\gamma$ -hydrogen atom and the carbonyl group is also fixed. Relevant examples are the 15-keto steroids. First, the distance between the 7 $\beta$ -hydrogen atom and the carbonyl oxygen, as judged from Dreiding models,<sup>13</sup> is 2.3 Å., which is even larger than that in 11-keto steroids

(9) G. Spitteller and M. Spitteller-Friedmann, *Monatsh.*, **95**, 257 (1964).

(10) (a) R. Srinivasan, *J. Am. Chem. Soc.*, **81**, 5061 (1959); (b) N. Dinh-Nguyen, R. Ryhage, S. Stållberg-Stenhagen, and E. Stenhagen, *Arkiv Kemi*, **18**, 393 (1961); (c) T. E. Dickelman, M.S. Thesis, M.I.T. (1962), quoted in ref. 6, p. 120; (d) J. Seibl and T. Gäumann, *Z. Anal. Chem.*, **197**, 33 (1963); (e) D. H. Williams, H. Budzikiewicz, and C. Djerassi, *J. Am. Chem. Soc.*, **86**, 284 (1964); (f) C. Beard, J. M. Wilson, H. Budzikiewicz, and C. Djerassi, *ibid.*, **86**, 269 (1964).

(11) D. H. Williams, J. M. Wilson, H. Budzikiewicz, and C. Djerassi, *ibid.*, **85**, 2091 (1963); D. H. Williams and C. Djerassi, *Steroids*, **3**, 259 (1964).

(12) (a) C. Djerassi, *Pure Appl. Chem.*, **9**, 159 (1964); (b) H. Budzikiewicz, C. Djerassi, and D. H. Williams, "Structure Elucidation of Natural Products by Mass Spectrometry," Vol. II, Holden-Day, Inc., San Francisco, Calif., 1964, Chapter 20.

(13) A. S. Dreiding, *Helv. Chim. Acta*, **42**, 1339 (1959).

(e.g., II), where the McLafferty rearrangement was shown<sup>11</sup> not to occur. Second, the mass spectrum<sup>14</sup> of the one 15-keto steroid which has been examined so far, namely 3 $\beta$ -hydroxycholestan-15-one (IIIa), displays a very prominent peak at  $m/e$  209. Its origin can be interpreted<sup>14</sup> very plausibly in terms of a McLafferty rearrangement to species a followed by homolysis of the allylically activated 12–13 bond with formation of ion b ( $m/e$  209). In order to test this assumption, a 7,7- $d_2$ - or 7 $\beta$ - $d_1$ -15-keto steroid would have to be synthesized, and the present paper is concerned with the realization of this objective.

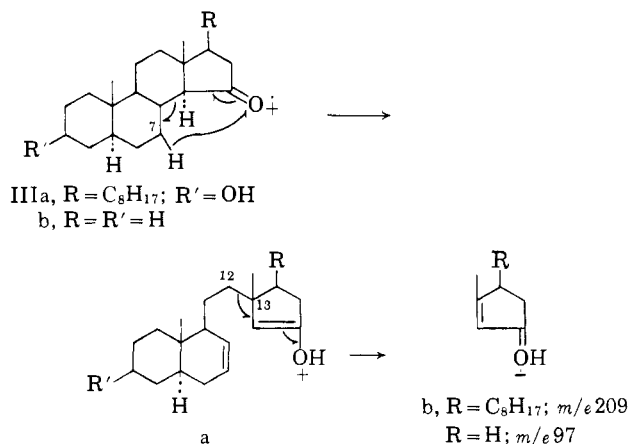

### Synthesis of 15-Keto Steroids

Aside from microbiological hydroxylations<sup>15</sup> and transformations<sup>16</sup> of relatively inaccessible naturally occurring steroids oxygenated at C-14 or C-15, only one chemical procedure of potential general applicability for the introduction of a 15-oxygen function has been reported<sup>17</sup> and this commences with steroidal  $\Delta^{5,7}$ -dienes. For our purposes—synthesis of a “naked” 15-keto steroid labeled with deuterium at C-7—neither microbiological procedures nor the intermediacy of naturally occurring 15-oxygenated steroids were convenient and we decided to develop another approach to the hitherto insufficiently studied 15-keto steroids. Since the publication of our preliminary communication<sup>18</sup> of this synthesis, another chemical method has been described by Cantrall and colleagues<sup>19</sup> which would also have been acceptable for our purposes.

Since 17-keto steroids are readily available, 5 $\alpha$ -androst-17-one (IV) was selected as the model substance. Ketalization to V and bromination with phenyltrimethylammonium bromide perbromide to the 16 $\alpha$ -bromo ketal VI was effected according to the literature directions<sup>20,21</sup> in somewhat improved yield

(14) H. Budzikiewicz and C. Djerassi, *J. Am. Chem. Soc.*, **84**, 1430 (1962).

(15) For recent examples see (a) C. Tamm, A. Gubler, G. Juhasz, E. Weiss-Berg, and W. Zürcher, *Helv. Chim. Acta*, **46**, 889 (1963); (b) J. de Flines, W. F. van der Waard, W. J. Mijls, and S. A. Szpilfogel, *Rec. trav. chim.*, **82**, 143 (1963); (c) P. Crabbé and C. Casas-Campillo, *J. Org. Chem.*, **29**, 2731 (1964).

(16) *Inter al.*, D. L. Klaas, M. Fieser, and L. F. Fieser, *J. Am. Chem. Soc.*, **77**, 3829 (1955); C. Djerassi, T. I. Grossnickel, and L. B. High, *ibid.*, **78**, 3166 (1956); A. Lardon, H. P. Sigg, and T. Reichstein, *Helv. Chim. Acta*, **42**, 1457 (1959); R. Tschesche and G. Wulff, *Ber.*, **94**, 2019 (1961); M. S. Ragab, H. Linde, and K. Meyer, *Helv. Chim. Acta*, **45**, 1794 (1962); C. R. Engel and G. Bach, *Steroids*, **3**, 593 (1964).

(17) D. H. R. Barton and G. F. Laws, *J. Chem. Soc.*, 52 (1954).

(18) C. Djerassi and G. von Mutzenbecher, *Proc. Chem. Soc.*, 377 (1963).

(19) E. W. Cantrall, R. Littell, and S. Bernstein, *J. Org. Chem.*, **29**, 64, 214 (1964).

(see Experimental) and the latter dehydrobrominated with potassium *t*-butoxide in boiling xylene<sup>22</sup> to the hitherto undescribed  $\Delta^{15}$ -5 $\alpha$ -androst-17-one ethylene ketal (VII). Cleavage with *p*-toluenesulfonic acid in aqueous acetone led to  $\Delta^{15}$ -5 $\alpha$ -androst-17-one (VIII) with the expected<sup>23</sup> ultraviolet absorption maximum at 233  $m\mu$ . Epoxidation with alkaline hydrogen peroxide in *t*-butyl alcohol solution afforded the 15 $\beta$ ,16 $\beta$ -epoxide IX (for stereochemistry see below), which upon reduction with hydrazine<sup>10f,24</sup> gave in variable yield (15–30%) the key intermediate,  $\Delta^{16}$ -5 $\alpha$ -androst-15 $\beta$ -ol (X). Oxidation by the Jones procedure<sup>25</sup> provided the unstable  $\Delta^{16}$ -5 $\alpha$ -androst-15-one (XI),<sup>26</sup> which was hydrogenated to the desired 5 $\alpha$ -androst-15-one (XII). An alternate and preferred route to this ketone consisted of catalytic hydrogenation of the allylic alcohol X to 5 $\alpha$ -androst-15 $\beta$ -ol (XIII) followed by Jones oxidation.<sup>25</sup>

The stereochemistry of the saturated 15-ketone XII at C-14 was established by the characteristic<sup>27</sup> positive ORD Cotton effect (see Figure 1) and by the fact that the substance was readily isomerized with base or even during chromatography on alumina to the 14 $\beta$  isomer XV with its expected<sup>27</sup> negative Cotton effect (see Figure 1). By determining the optical rotatory dispersion curve (see Figure 1) of the total product after equilibration with base, it was possible to calculate the composition of the equilibrium mixture (85% 14 $\beta$  (XV) vs. 15% 14 $\alpha$  (XII)). This value can now be used as the reference point against which the earlier measured<sup>28</sup> equilibria of steroidal and triterpenoid hydrindanones can be compared.

Lithium aluminum hydride reduction of 5 $\alpha$ -androst-15-one (XII) produced a mixture of two alcohols, both of which could be reoxidized to the starting ketone XII. The predominant levorotatory reduction product (75%) proved to be identical with the hydrogenation product of the allylic alcohol X. The alcohol, produced in smaller amount (25%) in the hydride reduction of XII, was dextrorotatory. This rotation relationship, when compared with that<sup>15b</sup> of other epimeric 15-hydroxy steroids, points toward the  $\beta$ -configuration for the major product (XIII), a conclusion which is supported by the observation that the

(20) L. Mamlok and J. Jacques, *Bull. Soc. Chim. France*, 484 (1960).

(21) A. Marquet, M. Dvolaitzky, H. B. Kagan, L. Mamlok, C. Ouannes, and J. Jacques, *ibid.*, 1822 (1961).

(22) See W. S. Johnson and W. F. Johns, *J. Am. Chem. Soc.*, **79**, 2005 (1957).

(23) F. Sondheimer, S. Burstein, and R. Mechoulam, *ibid.*, **82**, 3209 (1960); see also J. Fajkos, *Collection Czech. Chem. Commun.*, **23**, 1559 (1958).

(24) P. S. Wharton and D. H. Bohlen, *J. Org. Chem.*, **26**, 3615 (1961). See also P. S. Wharton, *ibid.*, **26**, 4781 (1961); C. Djerassi, D. H. Williams, and B. Berkoz, *ibid.*, **27**, 2205 (1962); Huang-Minlon and Chung-Tungshun, *Tetrahedron Letters*, 666 (1961); R. Sciaky and F. Facciano, *Gazz. Chim. Ital.*, **93**, 1028 (1963); W. R. Benn and R. M. Dodson, *J. Org. Chem.*, **29**, 1142 (1964).

(25) K. Bowden, I. M. Heilbron, E. R. H. Jones, and B. C. L. Weedon, *J. Chem. Soc.*, 39 (1946).

(26) In contrast to the isomeric  $\Delta^{16}$ -17-ketone VIII, which exhibits a maximum at the abnormally high (*vis-à-vis* simple  $\alpha,\beta$ -unsaturated cyclopentenones, see ref. 23) wave length of 233  $m\mu$ , the  $\Delta^{15}$ -15-ketone XI shows maximal absorption at a “normal” position (222.5  $m\mu$ ). Evidently the degree of strain in the polycyclic cyclopentenones must be related to the large wave length shifts, thus emphasizing the earlier (ref. 23) warning that structural conclusions cannot be based firmly on ultraviolet spectral data in  $\alpha,\beta$ -unsaturated five-membered ketones.

(27) C. Djerassi, W. Closson, and A. E. Lippman, *J. Am. Chem. Soc.*, **78**, 3163 (1956); C. Djerassi, R. Riniker, and B. Riniker, *ibid.*, **78**, 6362 (1956).

(28) N. L. Allinger, R. B. Hermann, and C. Djerassi, *J. Org. Chem.*, **25**, 922 (1960).

alcohol was resistant to acetylation at room temperature and required heating for effecting esterification. Also, attack of hydride would be expected to occur from the  $\alpha$ -side with predominant formation of the  $\beta$ -alcohol. The establishment of the stereochemistry of  $5\alpha$ -androstan-15 $\beta$ -ol (XIII) *ipso facto* settles that of the precursor oxido ketone IX.

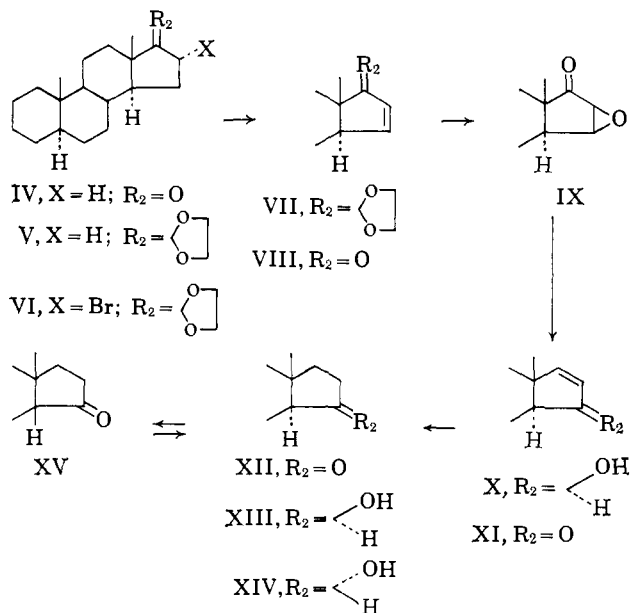

*Synthesis and N.m.r. Spectra of Deuterated Analogs of 5 $\alpha$ -Androstan-15-one.* As indicated in the introduction to this article, we required a 7,7- $d_2$ - or 7 $\beta$ - $d_1$ -labeled 15-keto steroid. In spite of the unsatisfactory results recorded in the literature<sup>29</sup> in the lithium aluminum deuteride reduction of 7 $\alpha$ -bromocholesteryl benzoate, we examined such a reaction path for the preparation of 5 $\alpha$ -androstan-15-one-7 $\beta$ - $d_1$  (XXIV). The starting material was the readily available 17,17-ethylenedioxy- $\Delta^5$ -androstene-3 $\beta$ -ol acetate (XVI)<sup>30</sup> which was brominated with N-bromosuccinimide in carbon tetrachloride solution, the  $\alpha$ -configuration of the bromine atom in the product XVII following<sup>31</sup> from the strong levorotation ( $[\alpha]_D -279^\circ$ ). Reduction with lithium aluminum deuteride afforded a product whose mass spectrometrically determined molecular weight was consistent with replacement of bromine by deuterium and hydrolysis of the 3-acetate function. However, the n.m.r. spectrum (angular methyl and olefinic proton region) demonstrated that this material consisted of the desired dehydroisoandrosterone-7 $\beta$ - $d_1$  17-ethylene ketal (XVIII) and the isomer XIX resulting from SN2' displacement. Separation was effected by Jones oxidation<sup>25</sup> and base isomerization, a treatment which is known<sup>32</sup> to afford  $\Delta^4$ -3-ketones from  $\Delta^5$ -3-alcohols. The resulting mixture of  $\Delta^4$ -androstene-3,17-dione-7 $\beta$ - $d_1$  17-ethylene ketal (XXI) and the  $\Delta^6$  isomer XX could now be separated easily, and the former was then subjected to lithium-ammonia reduction to the saturated ketone XXII followed by Wolff-Kishner reduc-

(29) E. J. Corey and G. A. Gregoriou, *J. Am. Chem. Soc.*, **81**, 3127 (1959).

(30) L. F. Fieser, *ibid.*, **76**, 1945 (1954).

(31) L. F. Fieser and M. Fieser, "Steroids," Reinhold Publishing Corp., New York, N. Y., 1959, p. 154.

(32) C. Djerassi, R. R. Engle, and A. Bowers, *J. Org. Chem.*, **21**, 1547 (1956).

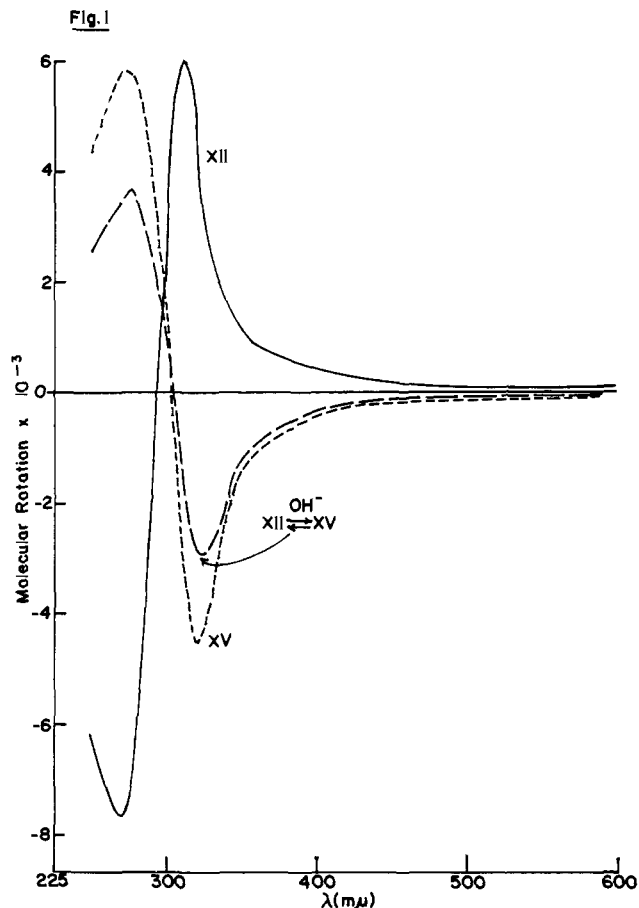

Figure 1. Optical rotatory dispersion curves (methanol solution) of 5 $\alpha$ -androstan-15-one (XII), 5 $\alpha$ -14 $\beta$ -androstan-15-one (XV), and their base-catalyzed equilibration mixture.

tion to 5 $\alpha$ -androstan-17-one-7 $\beta$ - $d_1$  ethylene ketal (XX-III). The remaining steps followed exactly those described above for the unlabeled analog V and thus provided the desired 5 $\alpha$ -androstan-15-one-7 $\beta$ - $d_1$  (XXIV) of over 90% isotopic purity. The corresponding 7 $\beta$ - $d_1$ ,14 $\beta$  isomer XXV could be obtained readily by conventional base treatment (see XII  $\rightarrow$  XV).

Finally, equilibration of 5 $\alpha$ -androstan-15-one (XII) with sodium in O-deuteriomethanol-deuterium oxide, and chromatographic separation of the isomer mixture, provided the 14,16,16- $d_3$ -labeled derivatives XXVI and XXVII of 5 $\alpha$ ,14 $\alpha$ - (XII) and 5 $\alpha$ ,14 $\beta$ -androstan-15-one (XV).

The configuration of the deuterium atom in 5 $\alpha$ -androstan-15-one-7- $d_1$  (XXIV) and its 14 $\beta$  isomer XXV could also be inferred from n.m.r. data. One might anticipate from earlier studies<sup>33</sup> that the equatorial 7 $\beta$ -proton in 5 $\alpha$ -androstan-15-one (XII) would be deshielded due to the proximity of the C-15 carbonyl function. Indeed, the n.m.r. spectrum of 5 $\alpha$ -androstan-15-one-14 $\alpha$ ,16,16- $d_3$  (XXVI) contains downfield signals corresponding to one proton at 2.65 p.p.m. The splittings are consistent<sup>34</sup> with one geminal interaction ( $J \leq 12$  c.p.s.) and 3 small vicinal interactions (axial-

(33) (a) D. H. Williams, N. S. Bhacca, and C. Djerassi, *J. Am. Chem. Soc.*, **85**, 2810 (1963); (b) R. Beugelmans, R. H. Shapiro, L. J. Durham, D. H. Williams, H. Budzikiewicz, and C. Djerassi, *ibid.*, **86**, 2823 (1964).

(34) See N. S. Bhacca and D. H. Williams, "Applications of NMR Spectroscopy in Organic Chemistry: Illustrations from the Steroid Field," Holden-Day, Inc., San Francisco, Calif., 1964, Chapter 3.

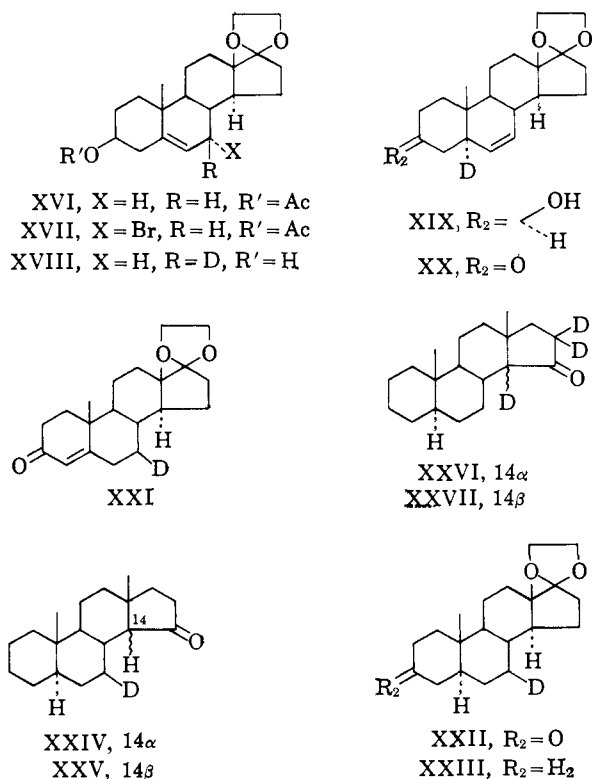

equatorial, axial-equatorial, and diequatorial) as required for a 7 $\beta$ -proton. This signal is absent in the n.m.r. spectrum of the 7-*d*<sub>1</sub> analog XXIV, a finding which supports strongly the assigned equatorial 7 $\beta$ -orientation of the deuterium atom.

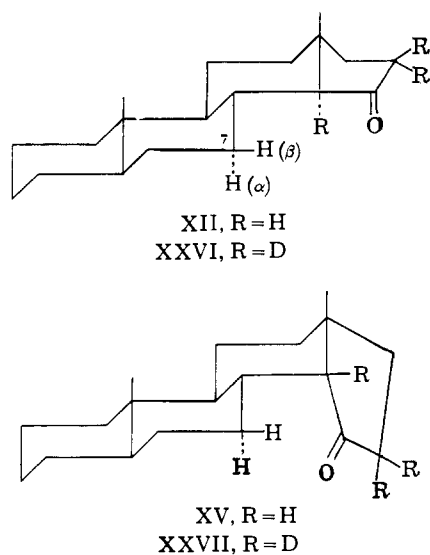

The n.m.r. spectrum of 5 $\alpha$ -androst-15-one-14 $\beta$ ,16,16-*d*<sub>3</sub> (XXVII) exhibits a very broad (half-band width 20 c.p.s.) one-proton signal centered at approximately 2.53 p.p.m. which cannot be due to hydrogens adjacent to the carbonyl group since these had been replaced by deuterium. This observation is consistent with deshielding of the 7 $\alpha$ -proton by the C-15 carbonyl group in the 14 $\beta$  isomer XXVII. As expected, this broad 2.53 p.p.m. signal remained unchanged in the n.m.r. spectrum of 5 $\alpha$ ,14 $\beta$ -androst-15-one-7-*d*<sub>1</sub> (XXV), an observation which is again consistent with the assigned stereochemistry (7 $\beta$ ) of the deuterium atom.

Independent proof for the configuration of the deuterium atom could also be provided in the following fashion.  $\Delta^5$ -Androst-3 $\beta$ -ol acetate (XXVIII) was brominated with N-bromosuccinimide in the manner described above for the corresponding 17-ethylene ketal XVI, and the resulting levorotatory 7 $\alpha$ -bromo derivative was reduced with lithium aluminum deuteride. The resulting mixture of  $\Delta^5$ -androst-3 $\beta$ -ol-7 $\beta$ -*d*<sub>1</sub> (XXXa) and  $\Delta^6$ -androst-3 $\beta$ -ol-5 $\alpha$ -*d*<sub>1</sub> (XXXIIIa) was most conveniently separated by conversion into the respective tosylates XXXIa and XXXIVa followed by solvolysis with potassium acetate in aqueous acetone. Such treatment provided a mixture of the cyclo steroid XXXVa, the 3 $\alpha$ -alcohol XXXVIa, and some diene. Chromatography on silica gel not only effected an efficient separation but at the same time caused rearrangement of the cyclo steroid XXXVa to the desired  $\Delta^5$ -androst-3 $\beta$ -ol-7 $\beta$ -*d*<sub>1</sub> (XXXa), which was thus obtained in a high state of purity. Epoxidation of its acetate XXXIIa with *m*-chloroperbenzoic acid followed by saponification of the acetate XXXVIIIa yielded 5 $\alpha$ ,6 $\alpha$ -oxidoandrost-3 $\beta$ -ol-7 $\beta$ -*d*<sub>1</sub> (XXXVIIa), while the corresponding 5 $\beta$ ,6 $\beta$ -oxide XLa was obtained by hypobromous acid addition to  $\Delta^5$ -androst-3 $\beta$ -ol-7 $\beta$ -*d*<sub>1</sub> acetate (XXXIIa) followed by base treatment of the bromohydrin XXXIXa.

The two epimeric oxides XXXVIIa and XLa, and their deuterium-free analogs XXXVIIb and XLb (prepared by substituting lithium aluminum hydride for lithium aluminum deuteride in the reduction of the 7 $\alpha$ -bromide XXIX), served as excellent substrates for establishing the orientation of the 7-deuterium atom by n.m.r. spectral measurements. Several recent publications<sup>35-37</sup> have commented upon the characteristic chemical shifts of the angular methyl proton signals associated with the presence of  $\alpha$ - and  $\beta$ -oxide rings terminating at C-5 and especially with the coupling constants of the epoxidic proton. Since the dihedral angle in 5 $\alpha$ ,6 $\alpha$ -oxides (e.g., XXXVII) between the 6 $\beta$ - and 7 $\alpha$ -protons is nearly 90°, a negligible coupling constant should be encountered, while the 28° angle between the 6 $\beta$ - and 7 $\beta$ -protons should result in a 4 c.p.s. splitting.<sup>35,37</sup> The 4 c.p.s. doublet centered at 2.89 p.p.m. in the n.m.r. spectrum of 5 $\alpha$ ,6 $\alpha$ -oxidoandrost-3 $\beta$ -ol (XXXVIIb) is thus in good agreement with observed and calculated literature values<sup>35,37</sup> based on closely related steroidal oxides. Most importantly, this signal collapsed to a singlet (2.88 p.p.m.) in the n.m.r. spectrum of the deuterated  $\alpha$ -oxide XXXVIIa, an observation which is only consistent with the 7 $\beta$ -orientation of the deuterium atom.

Similarly, in 5 $\beta$ ,6 $\beta$ -oxides,<sup>35,37</sup> a negligible splitting is predicted (and observed) for the 6 $\alpha$ ,7 $\alpha$ -protons, while a coupling constant of  $J = 2.5$  c.p.s. has been reported for the 6 $\alpha$ ,7 $\beta$ -protons. The present n.m.r. results (doublet in XLb centered at 3.06 p.p.m.,  $J = 3$  c.p.s., singlet in XLa) are in agreement with the literature results and again confirm the 7 $\beta$ -orientation of the deuterium atom. The chemical shifts of the angular methyl protons ( $\alpha$ -oxides XXXVII: C-18 0.65 p.p.m., C-19 1.07 p.p.m.;  $\beta$ -oxides XL: C-18

(35) A. D. Cross, *J. Am. Chem. Soc.*, **84**, 3206 (1962).

(36) D. J. Collins, J. J. Hobbs, and S. Sternhell, *Tetrahedron Letters*, 623 (1963).

(37) K. Tori, T. Komeno, and T. Nakagawa, *J. Org. Chem.*, **29**, 1136 (1964).

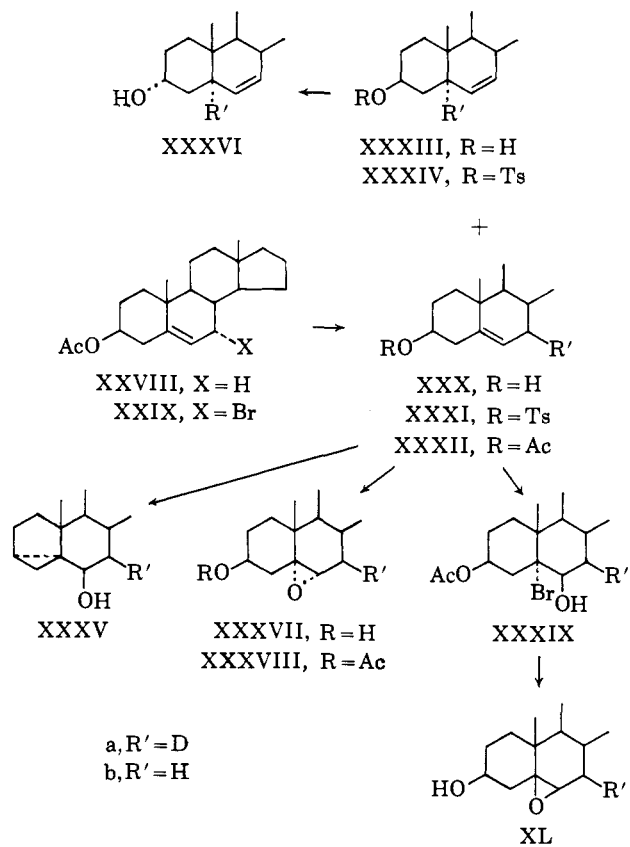

0.68 p.p.m., C-19 1.00 p.p.m.) are in agreement<sup>35, 37</sup> with the assigned stereochemistry at C-5 and C-6.

### Discussion of Mass Spectra

As indicated in the introduction to this paper, the principal reason for undertaking the rather lengthy synthetic work on 5 $\alpha$ -androstan-15-one-7 $\beta$ -d<sub>1</sub> (XXIV) was to examine whether the McLafferty rearrangement was involved in the genesis of this most important ion (see *m/e* 97) in the mass spectrum (Figure 2) of 5 $\alpha$ -androstan-15-one (XII) according to the sequence IIIB (= XII)  $\rightarrow$  a  $\rightarrow$  b (*m/e* 97). An inspection of the mass spectrum (Figure 3) of the 7 $\beta$ -d<sub>1</sub> analog XXIV shows that no more than 10% of the *m/e* 97 peak is shifted to *m/e* 98, thus demonstrating that the McLafferty rearrangement plays only a negligible role in this fragmentation. This observation is in accord with the earlier ones<sup>11</sup> among 11-keto steroids and strongly supports the conclusion<sup>12</sup> that a *critical interatomic distance* (<1.8 Å) between the  $\gamma$ -hydrogen atom and the carbonyl oxygen atom is required before the McLafferty rearrangement can occur.

A possible explanation for the formation of the *m/e* 97 ion is the intervention of a molecular ion such as c, in which the positive charge is carried on a tertiary center, followed by hydrogen transfer from C-9 to give ultimately the ion d (*m/e* 97). No reciprocal hydrogen transfer<sup>10f, 11</sup> seems to occur, since the hydrogen atoms at C-14 and C-16 are in no way involved in the formation of the *m/e* 97 species (see complete shift to *m/e* 100 in the mass spectrum (Figure 4) of 5 $\alpha$ -androstan-15-one-14 $\alpha$ ,16,16-d<sub>3</sub> (XXVI)).

Even more attractive is the assumption that the reaction proceeds through the  $\alpha$ -cleavage product e in which the primary radical site at C-16 captures a C-11

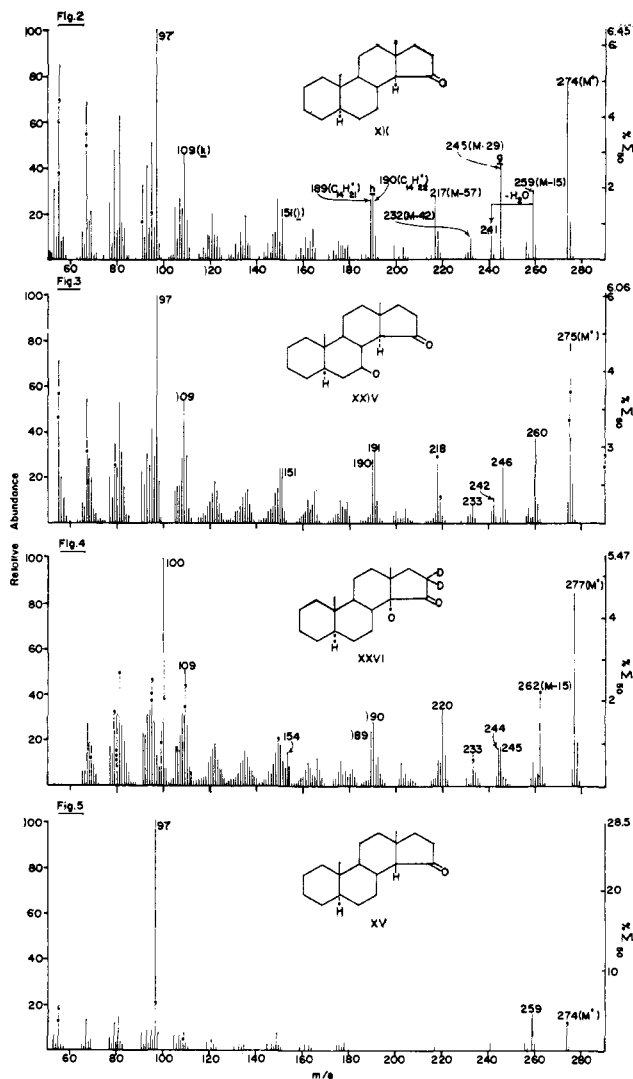

Figure 2. Mass spectrum of 5 $\alpha$ -androstan-15-one (XII).

Figure 3. Mass spectrum of 5 $\alpha$ -androstan-15-one-7 $\beta$ -d<sub>1</sub> (XXIV).

Figure 4. Mass spectrum of 5 $\alpha$ -androstan-15-one-14 $\alpha$ ,16,16-d<sub>3</sub> (XXVI).

Figure 5. Mass spectrum of 5 $\alpha$ ,14 $\beta$ -androstan-15-one (XV).

hydrogen atom with synchronous fission of the 12-13 bond yielding e'. Subsequent homolysis of the 8-14 linkage then furnishes the well-stabilized ion d' (*m/e* 97).

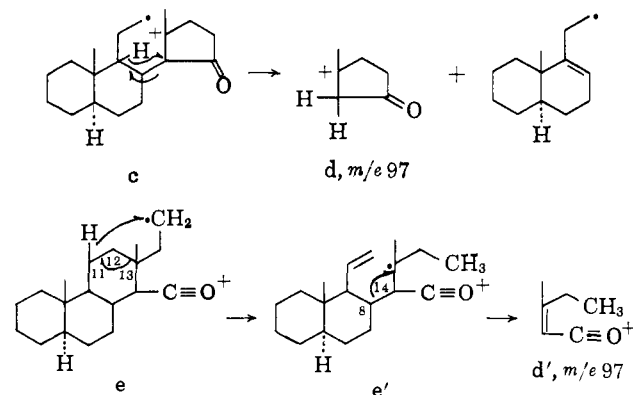

It is interesting to note that in the mass spectrum (Figure 5) of 5 $\alpha$ ,14 $\beta$ -androstan-15-one (XV) the ion of mass 97 carries a still larger proportion (28.5%  $\Sigma_{50}$ )

of the total ion current as compared to that (6.45%  $\Sigma_{50}$ ) of the  $14\alpha$  isomer XII (Figure 2). Less than 8% of the deuterium in  $5\alpha,14\beta$ -androstan-15-one- $7\beta$ - $d_1$  (XXV) is transferred to the charge-bearing fragment (d,  $m/e$  97).

The availability of the deuterated 15-ketones XXIV and XXVI has permitted a more precise interpretation of a number of other significant peaks in the mass spectrum (Figure 2) of  $5\alpha$ -androstan-15-one (XII).

The substantial peak at  $m/e$  259 is associated with the elimination of an angular methyl group, probably indiscriminately<sup>38</sup> from C-10 and C-13, rather than with the expulsion of C-16 and an additional hydrogen atom (*i.e.*, loss of a methyl radical from f, analogous to the situation encountered<sup>39</sup> in  $\beta$ -decalone), as demonstrated by the three mass unit shift to  $m/e$  262 in Figure 4. On the other hand, the loss of 29 mass units ( $m/e$  245 in Figure 2) involved only the removal of two nuclear carbon atoms according to the scheme  $e \rightarrow f \rightarrow g$  ( $m/e$  245), since this peak is not shifted in the mass spectrum (Figure 4) of the  $14\alpha,16,16$ - $d_3$  analog XXVI (thus requiring loss of all three deuterium atoms), but is found at  $m/e$  246 in the spectrum (Figure 3) of the  $7\beta$ - $d_1$  derivative XXIV.

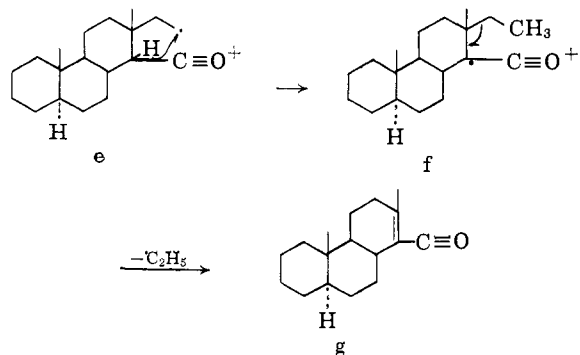

The shifts in the deuterated analogs (see Figures 3 and 4) of the peaks at  $m/e$  241, 232, and 217 (Figure 2) allow unambiguous assignments. The first is due to the loss of water from the  $M - 15$  species and does not involve the hydrogen atoms adjacent to the carbonyl group, while the  $m/e$  232 peak is caused by the removal of the elements of ketene (encompassed by C-15 and C-16) from the molecular ion. *A priori*, the  $M - 57$  peak ( $m/e$  217) could be attributed either to the further removal of ketene from the  $M - 15$  species or to loss of the entire ring A (carbon atoms 1-4 with their attached hydrogens as well as one additional hydrogen atom). That the latter alternative is the correct one is shown by the appearance of this peak at  $m/e$  220 in the mass spectrum (Figure 4) of  $5\alpha$ -androstan-15-one- $14\alpha,16,16$ - $d_3$  (XXVI).

The spectra of the labeled derivatives XXIV ( $m/e$  190 and 191 in Figure 3) and XXVI ( $m/e$  189 and 190 in Figure 4) demonstrate conclusively that the  $m/e$  189 and 190 peaks in the spectrum (Figure 2) of the parent ketone XII represent the  $C_{14}H_{21}^+$  and  $C_{14}H_{22}^+$  ions. Formally, only two fission processes, indicated by the broken lines in h, can be responsible for the ion of mass 190, while an additional hydrogen

(38) R. H. Shapiro, D. H. Williams, H. Budzikiewicz, and C. Djerassi, *J. Am. Chem. Soc.*, **86**, 2837 (1964).

(39) E. Lund, H. Budzikiewicz, J. M. Wilson, and C. Djerassi, *ibid.*, **85**, 1528 (1963).

transfer to the noncharged moiety must be associated with the genesis of the fragment of mass 189. No plausible mechanistic paths can be proposed at this stage for these species and the unusual multiple bond ruptures indicated in h are somewhat reminiscent of the equally unexplained genesis of the base peak ( $m/e$  175) in the mass spectrum<sup>40</sup> of 4,4-dimethyl- $5\alpha$ -androstan-3-one.

The  $m/e$  151 peak (Figure 2) is quite clearly due to cleavage of the 7-8 and 9-10 bonds in XII with transfer of one hydrogen atom to the charged species. This conclusion is supported by the appearance of this peak at  $m/e$  151 in Figure 3 and at  $m/e$  154 in Figure 4. Reasonable representations for this ion would be i or i'.

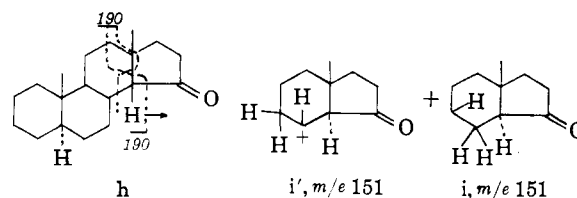

Finally, a plausible structure can also be attributed to the ion of mass 109, which remains unchanged in all three spectra (Figures 2-4) and hence must be  $C_8H_{13}^+$ . Its formation may be visualized as proceeding through the molecular ion j followed by transfer of the C-5 hydrogen atom to the oxygen-containing moiety and production of the allylic carbonium ion k ( $m/e$  109).

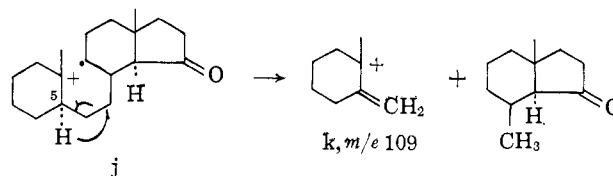

The present results support the conclusions<sup>12b</sup> reached earlier on the basis of work with deuterium labeled 3-<sup>38</sup> and 7-keto<sup>33b</sup> steroids that the carbonyl group in the presence of a large, alicyclic framework is not capable of "fixing" effectively the positive charge in the manner encountered, for instance, with the corresponding ethylene ketal or dimethylamino derivatives.<sup>41</sup> The data are most conveniently interpreted on the basis of ions in which the positive charge is frequently localized at a tertiary carbon center (*e.g.*, molecular ions c and j) rather than on the oxygen atom (*e.g.*, molecular ion e).

## Experimental<sup>42</sup>

$\Delta^{15}$ - $5\alpha$ -Androsten-17-one Ethylene Ketal (VII).  $5\alpha$ -Androstan-17-one (IV)<sup>43</sup> (5.75 g.), *p*-toluenesulfonic

(40) R. H. Shapiro and C. Djerassi, *Tetrahedron*, **20**, 1987 (1964).

(41) H. Budzikiewicz, C. Djerassi, and D. H. Williams, "Structure Elucidation of Natural Products by Mass Spectrometry," Vol. II, Holden-Day, Inc., San Francisco, Calif., 1964, Chapter 18.

(42) All melting points are uncorrected and were determined on the Kofler block. Optical rotations and infrared spectra were measured in chloroform solution, while deuteriochloroform was employed for the n.m.r. spectra, which were obtained on Varian 60 or 100 Mc. spectrometers. Chemical shifts are reported in  $\delta$ -units with tetramethylsilane ( $\delta = 0.00$  p.p.m.) as internal standard. We are indebted to Dr. Lois J. Durham (Stanford University) and Mr. N. S. Bhacca (Varian Associates) for the n.m.r. measurements and to Messrs. E. Meier and J. Consul for the microanalyses. All mass spectra were measured with a C.E.C. No. 21-103C mass spectrometer using an all-glass inlet system heated to 200° (isatran temperature 270°) with the ionizing energy being kept at 70 e.v. and the ionizing current at 50  $\mu$ a.

acid monohydrate (0.4 g.), ethylene glycol (5 cc.), and toluene (100 cc.) were heated under reflux and vigorous stirring for 20 hr. using a water separator. The usual isolation and recrystallization from ethyl acetate provided 5.13 g. of crystals (m.p. 140–145°) and a second crop (1.02 g.) melting at 133–145°, both crops being used in the next step; lit.<sup>20</sup> m.p. 145–146°. The bromination of 6.5 g. of the ketal in 50 cc. of freshly distilled tetrahydrofuran was performed with 8.0 g. of phenyltrimethylammonium bromide perbromide according to the literature directions<sup>21</sup> and provided two crops of needles, m.p. 145–149° (4.92 g.) and 135–143° (1.66 g.), of the 16-bromo-17-ketal VI.

The dehydrobromination of 28.7 g. of the bromo ketal was accomplished by heating it under reflux with vigorous stirring in an atmosphere of nitrogen with 900 cc. of dry xylene and 0.3 mole of freshly prepared dry potassium *t*-butoxide. Dilution with water, isolation of the product with ether, and recrystallization from methanol yielded 21 g. of the unsaturated ketal VII, m.p. 118.5–120°, and a second crop (1.93 g.), m.p. 95–105°. The analytical sample crystallized as brilliant plates exhibiting m.p. 120–121°,  $[\alpha]_D - 120^\circ$ .

*Anal.* Calcd. for  $C_{21}H_{32}O_2$ : C, 79.70; H, 10.19. Found: C, 79.66; H, 10.31.

$\Delta^{15-5\alpha}$ -Androsten-17-one (VIII). A solution of 10.5 g. of the ketal VII and 0.46 g. of *p*-toluenesulfonic acid monohydrate in 600 cc. of acetone and 60 cc. of water was stirred at room temperature for 5 hr. After concentrating at 25° to one-half its volume, water was added and the product extracted with ether. Recrystallization from hexane provided 6.86 g. of rhombic needles, m.p. 96–101°, and 0.58 g. of crystals, m.p. 80–96°. The analytical sample was obtained by chromatography on alumina followed by recrystallization from hexane; m.p. 98–101°,  $[\alpha]_D - 80^\circ$ ,  $\lambda_{max}^{EtOH} 233 m\mu$  ( $\epsilon$  7860),  $\lambda_{max}^{CHCl_3} 5.91 \mu$ .

*Anal.* Calcd. for  $C_{19}H_{28}O$ : C, 83.77; H, 10.36. Found: C, 83.94; H, 10.53.

15 $\beta$ ,16 $\beta$ -Oxido-5 $\alpha$ -androstan-17-one (IX). To a solution of 2.0 g. of  $\Delta^{15-5\alpha}$ -androsten-17-one (VIII) in 250 cc. of dry *t*-butyl alcohol was added with stirring 3.7 cc. of 4 *N* sodium hydroxide solution followed (after cooling to 15°) by the dropwise addition of 7.4 cc. of 30% hydrogen peroxide at such a rate (ca. 10 min.) that the temperature was maintained at 15°. After stirring for 18 hr. at room temperature ether and saturated salt solution was added, and the organic phase was washed successively with saturated salt solution, aqueous ferrous sulfate, water, acetic acid, water, sodium bicarbonate solution, and finally water. Recrystallization of the crystalline residue yielded 1.134 g. of fine needles, which were suitable for the next step. In order to obtain an analytical specimen, the material was chromatographed *rapidly* on neutral alumina (activity II) by eluting with hexane–benzene (9:1), and recrystallized from methanol. The colorless plates exhibited m.p. 137–138°,  $[\alpha]_D - 48^\circ$ ,  $\lambda_{max}^{CHCl_3} 5.78 \mu$ .

All thin layer chromatograms were performed on silica gel G (E. Merck, Darmstadt) with either methylene chloride or benzene–methanol (4:1) as developing solvent, the detection of the spots being accomplished by spraying with a 2% solution of ceric sulfate in 2 *N* sulfuric acid followed by heating.

(43) L. Ruzicka and A. C. Muhr, *Helv. Chim. Acta*, 27, 503 (1944).

*Anal.* Calcd. for  $C_{19}H_{28}O_2$ : C, 79.12; H, 9.79. Found: C, 79.14; H, 9.87.

$\Delta^{16-5\alpha}$ -Androsten-15 $\beta$ -ol (X). To a solution of 2.39 g. of the above oxido ketone IX (m.p. 120–129°) in 100 cc. of methanol was added at room temperature in an atmosphere of nitrogen with stirring 1.35 g. of 95% hydrazine in 10 cc. of methanol followed by the addition of 1 g. of acetic acid in 10 cc. of methanol. The colorless solution turned immediately deep yellow and gas evolution commenced which persisted for 5 min. The mixture was stirred for a total of 18 hr., whereupon half of the methanol was removed under reduced pressure without heating. Dilution with water and extraction with ether gave 1.38 g. of brown foam, which was chromatographed on 40 g. of neutral alumina (activity II). Elution with hexane–benzene (8:2) yielded 870 mg. of oily allylic alcohol X, which was homogeneous by thin layer chromatography. Trituration with cold hexane effected crystallization (m.p. 45–50°), and two recrystallizations from the same solvent led to 670 mg. of fine crystals, m.p. 76–77°,  $[\alpha]_D - 71^\circ$ . The yield ranged from 15 to 30% in different runs for no apparent reason.

*Anal.* Calcd. for  $C_{19}H_{30}O$ : C, 83.15; H, 11.02. Found: C, 83.25; H, 11.14.

Acetylation with acetic anhydride–pyridine at room temperature left much unchanged alcohol, as judged by thin layer chromatography, and heating at 50° for 12 hr. was required for complete acetylation. The oily acetate of X resisted all attempts at crystallization, even after column chromatography. The absence of ultraviolet absorption showed that no dehydration had occurred and a thin layer chromatographically homogeneous sample had  $[\alpha]_D - 146^\circ$ .

5 $\alpha$ -Androstan-15 $\beta$ -ol (XIII). The catalytic hydrogenation of 265 mg. of the allylic alcohol X in 15 cc. of ethyl acetate with 30 mg. of 10% palladized charcoal catalyst (room temperature, atmospheric pressure) was complete in 3 hr. Filtration of the catalyst, evaporation of the solvent, and trituration with methanol gave the saturated alcohol XIII (m.p. 69–70°) in over 90% yield. The analytical sample after recrystallization from methanol exhibited m.p. 75–76° (m.p. 80.5–81.5° after thorough drying),  $[\alpha]_D - 34^\circ$ .

*Anal.* Calcd. for  $C_{19}H_{32}O$ : C, 82.54; H, 11.66. Found: C, 82.22; H, 11.63.

The alcohol was virtually unchanged upon attempted acetylation at room temperature with acetic anhydride–pyridine. Acetylation could be effected by heating the mixture for 5 hr. at 70°. The resulting acetate was chromatographed on alumina, but the homogeneous product could not be crystallized;  $[\alpha]_D - 45^\circ$ ,  $\lambda_{max}^{CHCl_3} 5.80$  and  $8.0 \mu$  (broad).

$\Delta^{16-5\alpha}$ -Androsten-15-one (XI). Attempts to oxidize  $\Delta^{16-5\alpha}$ -androsten-15 $\beta$ -ol (X) with manganese dioxide in benzene failed, but oxidation by the Jones<sup>25</sup> procedure succeeded in spite of the instability of the unsaturated ketone. The 8 *N* chromic acid reagent<sup>25</sup> was added dropwise at –20° in an atmosphere of nitrogen<sup>32</sup> to a solution of 400 mg. of the alcohol in 15 cc. of pure acetone. The reaction mixture was immediately diluted with water, extracted with ether, and the residue chromatographed on 12 g. of silica gel G. Elution with hexane–benzene (3:2) gave 230 mg. of pure unsaturated ketone as judged by thin layer chroma-

tography. Crystallization from hexane provided crystals, m.p. 75–77°,  $[\alpha]_D +4^\circ$ ,  $\lambda_{\text{max}}^{\text{EtOH}}$  222.5  $\mu$  ( $\epsilon$  6780),  $\lambda_{\text{max}}^{\text{CHCl}_3}$  5.91 and 6.41  $\mu$ .

*Anal.* Calcd. for  $\text{C}_{19}\text{H}_{28}\text{O}$ : C, 83.77; H, 10.36. Found: C, 83.89; H, 10.40.

As demonstrated by thin layer chromatography, the pure ketone starts to decompose within two days as judged by the appearance of new spots.

*5 $\alpha$ -Androstan-15-one (XII).* (a) *By Oxidation of 5 $\alpha$ -Androstan-15 $\beta$ -ol (XIII).* To a solution of 236 mg. of the saturated alcohol XIII in 10 cc. of pure acetone was added at 0° over a period of 2 min. 8 *N* chromic acid reagent<sup>25</sup> until no more color change was noticeable. Dilution with water, extraction with ether, and crystallization of the residue from methanol led to 192 mg. of the ketone XII, m.p. 86–89°. Two recrystallizations from methanol furnished the analytical specimen, m.p. 92–93°,  $[\alpha]_D +30^\circ$ ,  $\lambda_{\text{max}}^{\text{CHCl}_3}$  5.81  $\mu$ , O.R.D. (Figure 1) in methanol (*c* 0.11):  $[\alpha]_{589} +35^\circ$ ,  $[\alpha]_{312} +2236^\circ$ ,  $[\alpha]_{270} -2822^\circ$ ,  $[\alpha]_{250} -2250^\circ$ .

*Anal.* Calcd. for  $\text{C}_{19}\text{H}_{30}\text{O}$ : C, 83.15; H, 11.02. Found: C, 82.97; H, 11.14.

(b) *By Catalytic Hydrogenation of  $\Delta^{16}$ -5 $\alpha$ -Androsten-15-one (XI).* Catalytic hydrogenation of the freshly prepared  $\alpha,\beta$ -unsaturated ketone XI in ethyl acetate solution with 10% palladized charcoal catalyst led to 5 $\alpha$ -androstan-15-one (XII), m.p. 91–93°, in 82% yield.

*Base-Catalyzed Equilibration of 5 $\alpha$ -Androstan-15-one (XII).* *Isolation of 5 $\alpha$ ,14 $\beta$ -Androstan-15-one (XV).* A mixture of 160 mg. of 5 $\alpha$ -androstan-15-one (XII), 100 mg. of sodium, 5 cc. of methanol, and 1 cc. of water was heated under reflux for 3 hr. After isolation with ether, the resulting semicrystalline residue (155 mg.) was found by thin layer chromatography to consist of approximately 80% 14 $\beta$  (XV) and 20% 14 $\alpha$  (XII) isomers. Careful chromatography on silica gel G and elution with hexane–benzene (1:1) gave 134 mg. of pure 14 $\beta$  isomer, m.p. 68–69°. The analytical sample crystallized from methanol as fine needles, m.p. 72–73°,  $[\alpha]_D -37^\circ$ ,  $\lambda_{\text{max}}^{\text{CHCl}_3}$  5.81  $\mu$ , O.R.D. (Figure 1) in methanol (*c* 0.092):  $[\alpha]_{589} -30^\circ$ ,  $[\alpha]_{322} -1660^\circ$ ,  $[\alpha]_{275} +2115^\circ$ ,  $[\alpha]_{250} +1580^\circ$ .

*Anal.* Calcd. for  $\text{C}_{19}\text{H}_{30}\text{O}$ : C, 83.15; H, 11.02. Found: C, 82.92; H, 11.28.

In order to determine spectropolarimetrically (see Figure 1) the composition of the equilibrium mixture, 10 mg. each of the 14 $\alpha$ - or 14 $\beta$ -ketones was dissolved in 1.5 cc. of methanol containing 10 mg. of sodium and heated under reflux for 3 hr. The product was extracted with ether and the rotatory dispersion curve determined on the total residue. Using the O.R.D. curves (Figure 1) of the pure isomers, it was thus possible to calculate the composition as 85% 14 $\beta$  (XV) vs. 15% 14 $\alpha$  (XII) when equilibration of the 14 $\alpha$  isomer XII was performed, while values of 87% 14 $\beta$  vs. 13% 14 $\alpha$  were encountered when the reaction was carried out with the pure 14 $\beta$  isomer XV.

By carrying out the equilibration in O-deuteriomethanol and deuterium oxide and subsequent purification by chromatography on silica gel, 5 $\alpha$ -androstan-15-one-14 $\beta$ ,16,16- $d_3$  (XXVII) and 5 $\alpha$ -androstan-15-one-14 $\alpha$ ,16,16- $d_3$  (XXVI) of nearly 90% isotopic purity (see Figure 4) were obtained.

*Lithium Aluminum Hydride Reduction of 5 $\alpha$ -Androstan-15-one (XII).* Reduction of the keto function was

effected by heating under reflux for 6 hr. 100 mg. of 5 $\alpha$ -androstan-15-one (XII) in 15 cc. of ether and 60 mg. of lithium aluminum hydride. The mixture was decomposed by addition of a saturated aqueous sodium sulfate solution and the ether phase was washed with water, dried, and evaporated. Thin layer chromatography showed the oily residue (90 mg.) to consist of two components, the more abundant one possessing the same  $R_f$  value as the previously obtained 5 $\alpha$ -androstan-15 $\beta$ -ol (XIII). Chromatography on 6 g. of alumina (activity II) and elution with hexane provided 64 mg. of the 15 $\beta$ -alcohol XIII (m.p. 75–76°), while elution with hexane–benzene (9:1) led to 20 mg. of the pure 5 $\alpha$ -androstan-15 $\alpha$ -ol (XIV), which crystallized from methanol as long needles, m.p. 161–163°,  $[\alpha]_D +42^\circ$ .

Jones oxidation<sup>25</sup> regenerated the 15-ketone XII.

*Anal.* Calcd. for  $\text{C}_{19}\text{H}_{32}\text{O}$ : C, 82.54; H, 11.66. Found: C, 82.44; H, 11.60.

*7 $\alpha$ -Bromo- $\Delta^5$ -androsten-3 $\beta$ -ol-17-one 3-Acetate 17-Ethylene Ketal (XVII).* A mixture of 600 mg. of  $\Delta^5$ -androsten-3 $\beta$ -ol-17-one 3-acetate 17-ethylene ketal (XVI),<sup>30</sup> 325 mg. of N-bromosuccinimide, 20 cc. of carbon tetrachloride, and a trace of benzoyl peroxide was heated under reflux for 10 min. with the aid of a 500-w. lamp. The succinimide was filtered and the filtrate evaporated to dryness at 25° under reduced pressure. Trituration with cold petroleum ether (b.p. 40–60°) caused crystallization; yield, 370 mg., m.p. 143–145°. Recrystallization from ether provided fine needles exhibiting m.p. 148–151°,  $[\alpha]_D -279^\circ$ , that decomposed upon standing in air and light for 2 days.

*Anal.* Calcd. for  $\text{C}_{23}\text{H}_{33}\text{BrO}_4$ : C, 60.92; H, 7.33; Br, 17.63. Found: C, 61.15; H, 7.12; Br, 17.84.

*17-Ethylene Ketals of  $\Delta^5$ -Androstene-3,17-dione-7 $\beta$ - $d_1$  (XXI) and  $\Delta^5$ -Androstene-3,17-dione-5 $\alpha$ - $d_1$  (XX).* To an ice cold solution of 1.26 g. of lithium aluminum deuteride in 200 cc. of ether in a current of nitrogen was added over a period of 45 min. 6.95 g. of the 7 $\alpha$ -bromide XVII dissolved in 100 cc. of tetrahydrofuran and 500 cc. of ether. The mixture was stirred at room temperature for 2 days, then decomposed by the sodium sulfate technique, and the crude product (4.25 g.) from the ether solution was chromatographed on 120 g. of alumina (activity II). Elution with benzene (containing 7.5% of ether) yielded 3.04 g. of material whose infrared spectrum displayed a moderately sized carbonyl band due to partial cleavage of the ketal group and which was, therefore, again treated with ethylene glycol and *p*-toluenesulfonic acid in boiling benzene solution in the conventional manner. The resulting crystalline product (3.06 g.) lacked infrared carbonyl absorption and was homogeneous by thin layer chromatography. Nevertheless, the n.m.r. spectral data and the subsequent oxidation showed that the product consisted of a mixture of the two isomeric alcohols XVIII and XIX.

The alcohol mixture was dissolved in 300 cc. of acetone, divided into two parts, cooled in ice, and each part treated separately with a slight excess (>1.5 cc.) of 8 *N* chromium trioxide solution.<sup>25</sup> After pouring into water, extracting with ether, washing thoroughly with brine solution, and evaporating to dryness, the residue was heated under reflux for 20 min. with 50 cc. of methanol containing 10 drops of 4 *N* sodium hydroxide in order to effect isomerization<sup>32</sup> of any  $\Delta^5$ -3-



one to the  $\Delta^4$ -3-keto isomer. The products from the two divided oxidations were then combined (2.28 g.) and chromatographed on 120 g. of alumina. Elution with hexane-benzene (4:1) and recrystallization from the same solvent mixture gave 190 mg. of  $\Delta^6$ -androstene-3,17-dione-5 $\alpha$ - $d_1$  17-ethylene ketal (XX), m.p. 215–216°,  $[\alpha]_D -116^\circ$ ,  $\lambda_{\text{max}}^{\text{CHCl}_3}$  5.88  $\mu$ , no selective absorption in the 240  $\mu\mu$  range. Mass spectrometry showed the compound to contain 92%  $d_1$  species.

*Anal.* Calcd. for  $\text{C}_{21}\text{H}_{29}\text{DO}_3$ : C, 76.10; H, 9.42. Found: C, 76.01; H, 9.12.

A total of 872 mg. of the desired  $\Delta^4$ -androstene-3,17-dione-7 $\beta$ - $d_1$  17-ethylene ketal (XXI) was eluted with hexane-benzene (2:3); recrystallization from petroleum ether provided long plates, m.p. 144–146°,  $\lambda_{\text{max}}^{\text{EtOH}}$  242  $\mu\mu$  ( $\epsilon$  18,000), containing 93%  $d_1$  species as determined by mass spectrometry. The substance proved to be identical by mixture melting point with the nondeuterated ketal<sup>44</sup> of m.p. 146–148°.

Finally, benzene-ether (9:1) removed from the column 219 mg. of  $\Delta^4$ -androstene-3,17-dione-7 $\beta$ - $d_1$  with m.p. 174–177°,  $[\alpha]_D +192^\circ$ , whose identity was established by comparison with authentic  $\Delta^4$ -androstene-3,17-dione.

*5 $\alpha$ -Androstan-17-one-7 $\beta$ - $d_1$  17-Ethylene Ketal (XX-III).* To a solution of 100 mg. of lithium in 80 cc. of liquid ammonia cooled to  $-45^\circ$  was added over a period of 5 min. a solution of 634 mg. of the  $\Delta^4$ -3-ketone XXI in 14 cc. of ether-dioxane (1:1). An additional 80 mg. of lithium was added and after stirring for 20 min. at  $-45^\circ$  ammonium chloride was added, the ammonia allowed to evaporate, and the residue partitioned between ether and water. Since the presence of some over-reduced alcohol was detected by thin layer chromatography, the total product was oxidized by the Jones procedure,<sup>25</sup> filtered in benzene solution through an alumina column, and then recrystallized from methanol; yield, 78%, m.p. 195–196°, lit.<sup>45</sup> 195–196° for deuterium-free analog of XXII.

*5 $\alpha$ -Androstane-3,17-dione-7 $\beta$ - $d_1$  17-ethylene ketal (X-XII, 620 mg.),* sodium hydroxide (1.0 g.), 2 cc. of 95% hydrazine, and 20 cc. of diethylene glycol were heated in an atmosphere of nitrogen for 1.5 hr. until the temperature of the vapor had risen to 195°, at which point refluxing was continued for 5 hr. Dilution with water, extraction with ether, and trituration of the residue with ethyl acetate furnished 560 mg. of *5 $\alpha$ -androstan-17-one-7 $\beta$ - $d_1$  ethylene ketal (XXIII),* m.p. 141–145°, whose identity was established by mixture melting point determination and thin layer chromatographic comparison with the nonlabeled analog IV.

All subsequent transformations to *5 $\alpha$ -androstan-15-one-7 $\beta$ - $d_1$  (XXIV)* and *5 $\alpha$ ,14 $\beta$ -androstan-15-one-7 $\beta$ - $d_1$  (XXV)* were performed as described for the unlabeled analogs.

*7 $\alpha$ -Bromo- $\Delta^5$ -androsten-3 $\beta$ -ol Acetate (XXIX).* The bromination of  $\Delta^5$ -androsten-3 $\beta$ -ol acetate (XXVIII)<sup>46,47</sup>

(44) H. L. Herzog, M. A. Jevnik, M. E. Tully, and E. B. Hershberg, *J. Am. Chem. Soc.*, **75**, 4425 (1953).

(45) A. Marquet, H. B. Kagan, M. Dvolaitzky, J. Lematre, and J. Jacques, *Bull. Soc. Chim. France*, 539 (1960).

(46) Prepared by acetylation of the Wolff-Kishner reduction product of dehydroisoandrosterone; see R. H. Shapiro and C. Djerassi, *J. Am. Chem. Soc.*, **86**, 2825 (1964).

(47) N. A. Milas and C. R. Milone, *ibid.*, **68**, 738 (1946); L. Norymberska, J. Norymberski, and A. Olalde, *ibid.*, **70**, 1256 (1948).

with N-bromosuccinimide was effected in 57% yield as described above for the corresponding 17-ketal XVI, and the bromide was recrystallized from hexane to afford prisms melting at 126–127°,  $[\alpha]_D -309^\circ$ .

*Anal.* Calcd. for  $\text{C}_{21}\text{H}_{31}\text{BrO}_2$ : C, 63.43; H, 7.84; Br, 20.10. Found: C, 63.46; H, 7.75; Br, 19.90.

*$\Delta^5$ -Androsten-3 $\beta$ -ol-7 $\beta$ - $d_1$  (XXXa).* The above described 7 $\alpha$ -bromide XXIX (1.0 g.) in 100 cc. of absolute ether was stirred at room temperature for 20 hr. with 300 mg. of lithium aluminum deuteride, and the excess reagent was decomposed with ethyl acetate followed by saturated sodium sulfate solution and anhydrous sodium sulfate. The solid cake was filtered and washed with ether, and the ether solution washed, dried, and evaporated. The crystalline residue (870 mg.) was homogeneous by thin layer chromatography, but n.m.r. measurements (double signals for C-19 methyl protons at 0.8 p.p.m. (XXXIII) and 1.02 p.p.m. (XXX) as well as olefinic signals centered near 5.4 p.p.m. corresponding to ca. 1.5 hydrogens) demonstrated that approximately equal amounts of the two isomeric olefins XXXa and XXXIIIa were present.

The mixture was converted to the tosylates XXXIa and XXXIVa by allowing it to stand for 24 hr. at room temperature with 10 cc. of pyridine and 1 g. of *p*-toluenesulfonyl chloride. The resulting tosylate mixture, which was again homogeneous by thin layer chromatography, was dissolved in 90 cc. of acetone and heated under reflux for 24 hr. with 1.7 g. of potassium acetate and 35 cc. of water. The acetone was removed under reduced pressure and the product isolated with ether to yield an oil which on a thin layer chromatogram (benzene containing 5% ether) displayed four spots in the following order of increasing polarity: a diene, the unreacted tosylate mixture (XXXIa and XXXIVa), the 3,5-cyclo steroid XXXVa, and the  $\Delta^6$ -3 $\alpha$ -alcohol XXXVIa.

This mixture was chromatographed on 200 g. of silica gel (Light's) yielding 105 mg. of diene (hexane), 100 mg. of unreacted tosylates (hexane containing 10% benzene), 150 mg. of the  $\Delta^6$ -3 $\alpha$ -alcohol XXXVIa (benzene), and 250 mg. of the required  $\Delta^5$ -androsten-3 $\beta$ -ol-7 $\beta$ - $d_1$  (XXXa), m.p. 134–135°,  $[\alpha]_D -74^\circ$  (dioxane), whose melting point was undepressed by admixture with the unlabeled analog XXXb (lit.<sup>47</sup> m.p. 136–137°,  $[\alpha]_D -76^\circ$  (dioxane)) prepared by the same procedure but replacing lithium aluminum deuteride by lithium aluminum hydride. The purity of the  $\Delta^5$ -alcohol was confirmed by the n.m.r. spectrum (three proton singlet at 1.02 p.p.m. due to C-19 methyl protons).

No cyclo steroid XXXVa was encountered during the preparative chromatogram, because a model experiment with authentic<sup>48</sup> 3 $\alpha$ ,5 $\alpha$ -cycloandrostan-6 $\beta$ -ol (XXXVb) showed it to be rearranged quantitatively to the  $\Delta^5$ -3 $\beta$ -alcohol XXXb by contact with Light's silica gel for several hours. A contact time of 10–15 min. was insufficient for this rearrangement and thus explains why the cyclo steroid XXXV is detectable by thin layer chromatography on silica gel.

*$\Delta^5$ -Androsten-3 $\beta$ -ol-7 $\beta$ - $d_1$  acetate (XXXIIa)* was prepared from the alcohol XXXa by conventional acet-

(48) A. Butenandt and L. A. Suranyi, *Ber.*, **75**, 591 (1942), report this substance as an oil, but we were able to crystallize it from methanol, m.p. 55–58°,  $[\alpha]_D +29^\circ$ .

ylation with acetic anhydride and pyridine at room temperature and exhibited the same melting point (m.p. 92–94°) as the unlabeled material XXXIb.<sup>47</sup>

5 $\alpha$ ,6 $\alpha$ -Oxidoandrostan-3 $\beta$ -ol-7 $\beta$ -d<sub>1</sub> (XXXVIIa). The acetate XXXIIa (80 mg.) in 2 cc. of chloroform was left at room temperature for 1 hr. with 80 mg. of *m*-chloroperbenzoic acid, ether was then added, and the excess peracid was removed by washing with dilute sodium carbonate solution. After washing with water and drying, the ether was evaporated and the crystalline oxide XXXVIIIa shown to be identical in terms of melting point and thin layer chromatographic mobility with a sample of the unlabeled analog XXXVIIIb, m.p. 111–112°, [ $\alpha$ ]<sub>D</sub> – 80°.

*Anal.* Calcd. for C<sub>21</sub>H<sub>32</sub>O<sub>3</sub>: C, 75.86; H, 9.70. Found: C, 75.72; H, 9.49.

Saponification of the acetate XXXVIIIa was effected by heating under reflux for 2 hr. with 1% methanolic potassium hydroxide solution. Crystallization from hexane yielded the pure 5 $\alpha$ ,6 $\alpha$ -oxidoandrostan-3 $\beta$ -ol-7 $\beta$ -d<sub>1</sub> (XXXVIIa), whose melting point (152–153°) was not depressed upon admixture with an authentic sample<sup>49</sup> of the unlabeled oxide XXXVIIb ([ $\alpha$ ]<sub>D</sub> – 92°).

(49) A. Butenandt and L. A. Suranyi, *Ber.*, **75**, 597 (1942).

*Anal.* Calcd. for C<sub>19</sub>H<sub>30</sub>O<sub>2</sub>: C, 78.57; H, 10.41. Found: C, 78.36; H, 10.16.

5 $\beta$ ,6 $\beta$ -Oxidoandrostan-3 $\beta$ -ol-7 $\beta$ -d<sub>1</sub> (XLa).  $\Delta^5$ -Androsten-3 $\beta$ -ol-7 $\beta$ -d<sub>1</sub> acetate (XXXIIa) (140 mg.) in 7 cc. of dioxane and 1.5 cc. of water was left at room temperature for 1 hr. with 0.46 cc. of 9% perchloric acid and 76 mg. of *N*-bromoacetamide, and then poured into sodium thiosulfate solution. Extraction with ether, washing, drying, and evaporation afforded the crude crystalline bromohydrin XXXIXa<sup>50</sup> which was dissolved in 15 cc. of methanol and heated under reflux for 2 hr. with 300 mg. of potassium hydroxide dissolved in 1 cc. of water. Isolation with ether and preparative chromatography on one silica gel H plate (20 × 20 cm.) in ether yielded 75 mg. of the  $\beta$ -oxide XLa, m.p. 172–174°. Recrystallization from ethyl acetate provided 48 mg. of the pure substance, whose melting point (m.p. 183–185°) was not depressed when mixed with a sample of unlabeled  $\beta$ -oxide XLb (m.p. 182–183°, [ $\alpha$ ]<sub>D</sub> – 16°).

*Anal.* Calcd. for C<sub>19</sub>H<sub>30</sub>O<sub>2</sub>: C, 78.57; H, 10.41. Found: C, 78.39; H, 10.22.

(50) In the nondeuterated series, 5 $\alpha$ -bromoandrostan-3 $\beta$ ,6 $\beta$ -diol 3-acetate (XXXIXb) was purified by recrystallization from methanol; m.p. 173–174°, [ $\alpha$ ]<sub>D</sub> – 61°. *Anal.* Calcd. for C<sub>21</sub>H<sub>33</sub>BrO<sub>3</sub>: C, 61.01; H, 8.05. Found: C, 60.68; H, 7.89.

## A Nuclear Magnetic Resonance Study of the 2-Haloethylamines

P. L. Levins and Z. B. Papanastassiou

Contribution from Arthur D. Little, Inc., Cambridge, Massachusetts 02140.

Received October 7, 1964

The rates and mechanism of solvolysis of 2-fluoroethylamine (II) and bis(2-fluoroethyl)amine (IV) in basic deuterium oxide solution have been studied by nuclear magnetic resonance and compared with their chloro analogs. The fluoroethylamines solvolyze by first-order kinetics through the same aziridinium intermediates as the chloroethylamines, but the chloro amines are 16–128 times more reactive than the fluoro amines. Application of n.m.r. techniques to 2,2'-dichloro-*N*-methyl-diethylamine (VI) allowed us to observe simultaneously the disappearance of starting amine, formation and reaction of the aziridinium intermediate, and formation of the piperazinium product.

In connection with our studies on potential carcinolytic agents<sup>1</sup> we have found nuclear magnetic resonance to be a valuable aid in interpreting the *in vitro* reactions of 2-haloethylamines which involve aziridines as reactive intermediates or as products. The widespread use of 2-haloethylamines in biological studies as alkylating agents has led to extensive studies of their chemistry and biochemistry.<sup>2–5</sup> When the halogen is chlorine,

(1) Z. B. Papanastassiou and R. J. Bruni, Abstracts, 144th National Meeting of the American Chemical Society, Los Angeles, Calif., April 1963, p. 42L.

bromine, or iodine, the reactions proceed under many conditions through an intermediate aziridinium ion to hydrolysis or alkylation products. The chemistry of the fluoro analogs was not clearly defined. Chapman and James<sup>6</sup> found that 2-fluoroethylamines did not solvolyze under the conditions of their experiments whereas the chlorine and bromine analogs reacted normally. Although Nemetz and Tzybaeva<sup>7</sup> observed solvolysis of 2-fluoroethylamines, they were unable to decide whether the solvolysis proceeded by a normal S<sub>N</sub>2 mechanism or through an aziridinium intermediate.

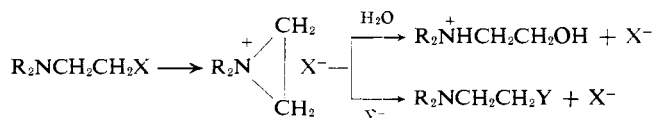

(2) J. D. P. Graham in "Progress in Medicinal Chemistry," Vol. 2, G. P. Ellis and G. B. West, Ed., Butterworth and Co., London, 1962, Chapter 4.

(3) W. C. J. Ross, "Biological Alkylating Agents," Butterworth and Co., London, 1962.

(4) C. C. Price, *Ann. N. Y. Acad. Sci.*, **68**, 657 (1958).

(5) P. D. Bartlett, S. D. Ross, and C. G. Swain, *J. Am. Chem. Soc.*, **71**, 1415 (1949), and previous papers.

(6) N. B. Chapman and J. W. James, *J. Chem. Soc.*, 2103 (1954).

(7) V. G. Nemetz and G. G. Tzybaeva, *Tr. Leningr. Tekhnol. Inst. im. Lensovetu*, **60**, 56 (1960); *Chem. Abstr.*, **56**, 7111b (1962).